

## Design software for prestressed CFRP strips

W. vom Berg & I. Dabrowski  
*bow consultants, Braunschweig, Germany*

J. Scherer  
*S&P Clever Reinforcement Company AG, Brunnen, Switzerland*

**ABSTRACT:** In recent years systems with externally bonded prestressed CFRP strips have been developed and applied for the strengthening of concrete structures. Main objective besides the strengthening effect is to improve the serviceability of the strengthened member by introducing prestressing forces counteracting the external loads. A new prestressing system for prefabricated CFRP strips has lately been developed by S&P Clever Reinforcement Company AG in Switzerland. It consists of a conventional prefabricated CFRP strip and steel anchor plates glued over the strip and bolted to the concrete. As the design of strengthening measures with prestressed FRP strips is a very complex task, bow consultants upgraded their design software *FRP Lamella* for flexural and shear strengthening with FRP systems and included the application of the S&P prestressing system as well as the S&P mechanical end anchorage system for unstressed strips. The design calculation for strengthening measures using prestressed FRP strips divides into three different proofs. At maximum bending moment, the required flexural capacity of the strengthened cross-section has to be checked. At the end anchorages, the effective transmission of the expected FRP tensile forces to the concrete has to be ensured. Therefore the capacity of the anchorage device has to be determined by testing. The third check of the bond capacity in-between the anchorages is comparable to unstressed FRP strips.

### 1 INTRODUCTION

#### 1.1 *CFRP strips as externally bonded FRP reinforcement*

For many years fibre reinforced polymers (FRP) have been used as externally bonded reinforcement particularly for strengthening of concrete elements. At the beginning, the main application was flexural strengthening with manual laminated carbon sheets. Shortly afterwards, prefabricated CFRP strips of carbon fibres embedded in an epoxy resin matrix came on the market. Due to the permanent control of the composite's parameters in the production line, the uncertainties of fibre/matrix ratio and misalignment of the fibres due to manual lamination could be avoided.

Usually the FRP strips are simply bonded to the concrete surface without prestress. In this case debonding becomes critical not only at the strip ends but also at other locations of high bond stresses due to concentrated loads, yielding of the internal rebars etc. (Neubauer 2001). To prevent debonding, a limitation of the maximum FRP strain was introduced in most FRP design guidelines. As carbon fibres are linear elastic, consequently the exploitation of the material is reduced to only 40 – 60 % of the tensile strength.

#### 1.2 *Prestressing of CFRP strips*

To increase the efficiency of the expensive material, systems with prestressed CFRP strips have been developed and applied in the last years. Main objective besides the strengthening effect is to improve the serviceability of the concrete element by introducing forces counteracting

the external loads. In contrast to unstressed FRP strengthening, which has only minimal influence on the deflections due to the small FRP cross-section, crack width and deflections can be significantly reduced by introducing prestress to the concrete element.

For flexural strengthening, the prestressed FRP strip is bonded to the tension face of the concrete element. The prestressing force introduces axial compression to the concrete and a bending moment as the FRP strip is located eccentrically to the element's gravity axis.

The total FRP stress is composed of prestress and additional stress due to subsequently applied loads. This leads to a higher exploitation of the FRP material. As the prestress is applied before hardening of the adhesive, the prestressing force does not cause bond stresses. Like this, prestressed strips are not more prone to debonding than unstressed FRP.

## 2 PRESTRESSING SYSTEM FOR FRP STRIPS

### 2.1 Description of the system

A new prestressing system for FRP strips has recently been developed by S&P Clever Reinforcement Company AG in Switzerland. It consists of a conventional prefabricated CFRP strip and steel anchor plates glued over the strip and bolted to the concrete at the strip ends. Temporary clamps and a hydraulic jack are used for the prestressing procedure.

The prestressing system fits to all available *S&P Lamelle CFK* strips having a width of 50 to 100 mm. These strips are 1.2 mm or 1.4 mm thick and the modulus of elasticity amounts to 160'000 N/mm<sup>2</sup>. They can be prestressed with an initial strain of 4–6 ‰, which leads to prestressing forces of 39 – 137 kN per strip.

The prefabricated strips are bonded to the concrete element over the whole length with a two-component epoxy adhesive. The strip ends are glued between the concrete surface and the anchor plates that are bolted to the concrete element. The anchor plates with dimensions of 220 x 400 x 12 (mm) are made of steel Fe 360, yield strength 235 N/mm<sup>2</sup>. They are fastened to the concrete by eight galvanized self-undercutting anchor bolts, grade 8.8, drill diameter 20 mm and effective anchorage depth 100 mm. The anchor bolts are suitable for uncracked and cracked concrete and can be upgraded for dynamic loads. In Figure 1 the complete system during installation including jack, clamps etc. is depicted.

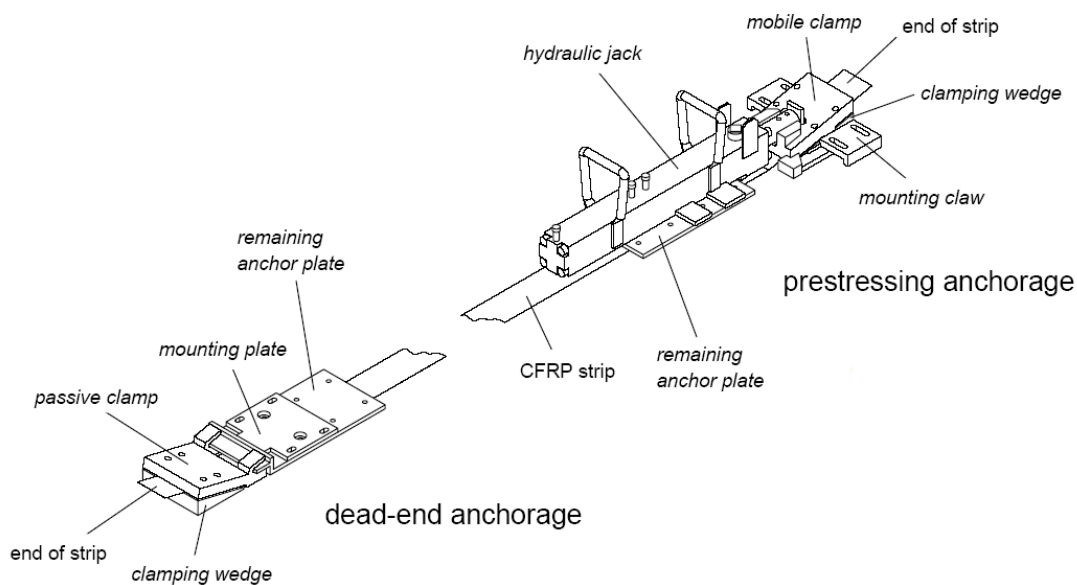

Figure 1. Prestressing system for FRP strips during installation

## 2.2 Application of the system

In the first step, the bolts for the anchor plates are installed. Then the FRP strip is glued to the concrete, the anchor plates are glued over the FRP strip and screwed to the bolts. Spacer screws provide a 6 mm glue-filled gap between anchor plate and concrete, allowing the CFRP strip to slide underneath the anchor plate while being prestressed. The strip ends are attached to temporary clamps beyond the anchor plates. At the dead-end anchorage, the passive clamp rests against the anchor plate. A hydraulic jack is installed on the other anchor plate and the jacking piston pushes the mobile clamp outwards to stress the FRP strip. In the end position, the hydraulic jack is locked and remains in this position for 24 h until complete hardening of the adhesive. Finally, the jack and the temporary clamps are detached and removed. Only the FRP strip and the rectangular anchor plates remain on the structure.

## 2.3 Mechanical principals of the anchorage devices

For the described system, the end anchorage of the strip is ensured by a combination of adhesive bond and dowel action. Instead of an active clamping force, applied by tensioned anchor bolts, the adhesive bond capacity is increased by a self-induced passive clamping force: the anchor plate, which is both glued and bolt-anchored to the concrete, impedes vertical displacement of commencing bond cracks in the concrete cover of the rebars.

In Figure 2, the forces over a segment  $\Delta x$  of the anchor plate are shown. The opening of commencing bond cracks is impeded by the anchor plate. The anchors obtain a tensile force  $N_D$ , exerting a vertical clamping pressure  $\sigma_n$  on the CFRP strip, which considerably increases the bond strength. Owing to the roughness of the bond crack surface, the magnitude of this “self induced” clamping pressure corresponds to the force of the strip. It does not depend on actively tensioned bolts and will therefore not decrease over time due to relaxation or concrete creep.

The anchor is not susceptible to pull-out failure as the tensile force  $N_D$  is an internal force, being in equilibrium with the clamping pressure. As mentioned previously, part of the force is carried by dowel action, depicted as  $V_D$  in Figure 2.

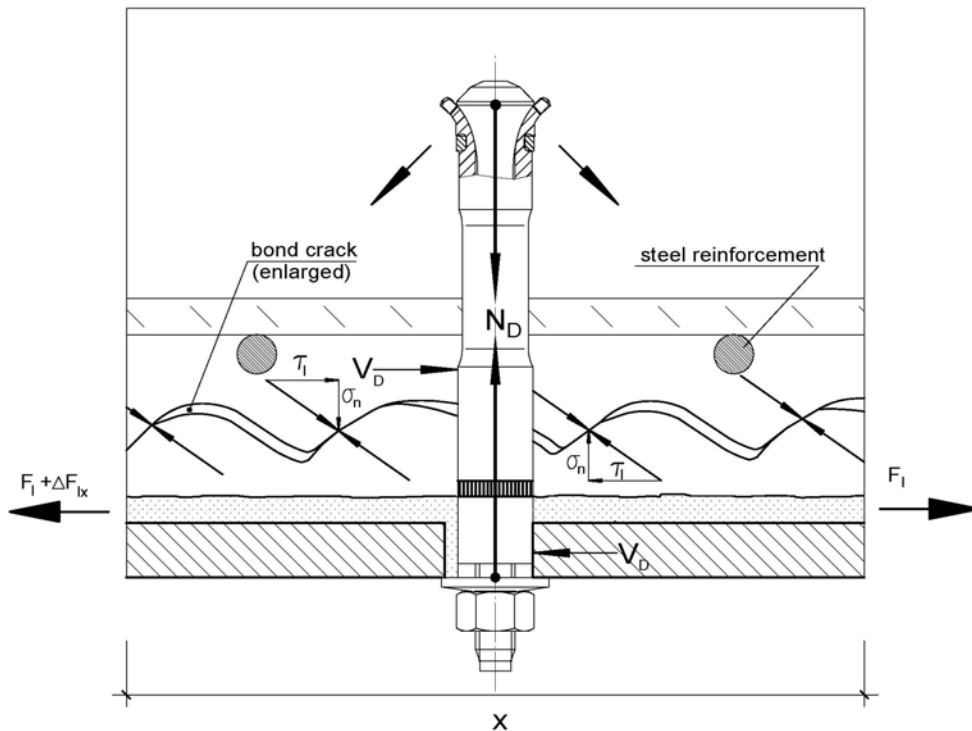

Figure 2. Principle of the anchorage: adhesive bond  $\tau$  with self-induced clamping pressure  $\sigma_n$  and dowel action  $V_D$

## 2.4 Testing of the system

The first tests of the anchorage prototype were carried out at the College of Engineering and Architecture of Fribourg, Switzerland (Suter & Jungo, 2001). They confirmed the efficiency of the whole system and furthermore gave hints for the enhancement of the anchorage devices. To simplify and shorten the prestressing procedure, temporary clamps were developed, that are able to grip the FRP strips only by dry clamping and friction.

The final system has been tested at the Institute for Testing of Building Materials in Braunschweig, Germany. 3 m long CFRP strips were mounted to a concrete slab according to the manufacturer's instructions and were prestressed to  $\varepsilon_f = 7.25 \text{ ‰}$ . From these test results the design recommendations quoted below were developed. Additionally a long-term testing was carried out for 6 months, but no measurable anchorage slip was observed. Also the fatigue testing showed excellent behaviour of the CFRP strips and the anchorages. This test ended by fatigue failure of internal steel reinforcement.

## 3 DESIGN CALCULATIONS

For prestressed FRP strips, the prestrain due to FRP prestressing and the additional strain induced by the loads are added up at each point of the strip. Figure 3 shows this effect for an externally prestressed concrete element.

$$\varepsilon_{f,d} = \varepsilon_{f,\text{prestress},d} + \varepsilon_{f,\text{load},d} \quad (1)$$

The total FRP strain has to keep the tensile capacity of the FRP material. The maximum FRP strain should be limited to 12 ‰, which equals about 80 % of the FRP tensile capacity.

$$\varepsilon_{f,\text{max},d} = 12.0 \text{ ‰} \quad (2)$$

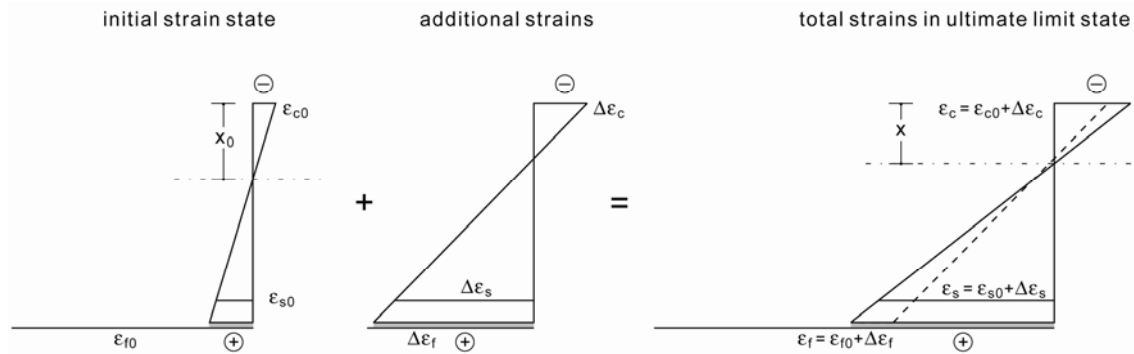

Figure 3. Superposition of initial strain state and additional strains due to loading on a concrete element that is externally strengthened with prestressed FRP strips.

The prestress is constant over the whole strip length. The allowable prestress is determined by the anchorage capacity. It is recommended to prestress the FRP strips with a strain of 4 to 6 ‰ which equals about 30 to 40 % of the FRP tensile strength.

$$\varepsilon_{f,\text{prestress},d} = 4 \text{ to } 6 \text{ ‰} \quad (3)$$

From the tests described and from other available tests (Suter & Jungo 2001; Tan et al. 2002) as well as from theoretical reasoning, an allowable design value of the total CFRP strain at the anchorage of  $\varepsilon_{f,A,d} = 6.50 \text{ ‰}$  was derived. This includes a safety factor of  $\gamma_A = 1.3$ . The prestress and load components may vary within this limit depending on the structural requirements, e.g.  $\varepsilon_{f,\text{prestress},d} = 5.00 \text{ ‰}$ ,  $\varepsilon_{f,\text{Load},A,d} = 1.50 \text{ ‰}$ .

$$\varepsilon_{f,A,d} = \varepsilon_{f,A,k} / \gamma_A = 8.5 \text{ ‰} / 1.3 = 6.5 \text{ ‰} \quad (4)$$

The adhesive bond of the FRP strips is only stressed by the additional FRP strain due to loading. This corresponds to a strengthening scheme with unstressed externally bonded strips. To avoid debonding between the end anchorages, the additional FRP strain should be limited accordingly.

Additionally, the following has to be considered: It is necessary to examine the effect of the applied prestress on the structure to ensure that the prestress does not go astray in adjacent parts of the structure. For dynamically loaded structures, the internal steel reinforcement must be checked for fatigue. As the adhesive bond in the anchorage is subjected to long term loading, the allowable temperature is restricted to 30°C for long term and to 35°C for short-term temperature.

#### 4 DESIGN SOFTWARE

As the design of strengthening measures with prestressed FRP strips is a very complex task the software *FRP Lamella* may help you with the design calculations. This software was especially developed for all kinds of flexural and shear strengthening with various FRP systems.

*FRP Lamella* is adapted to different national concrete design standards and FRP guidelines like Eurocode, German DIN code, British Standard and FRP guideline TR 55, American ACI codes, Dutch NEN code and FRP guideline CUR 91, Italian FRP guideline CNR 200 etc.

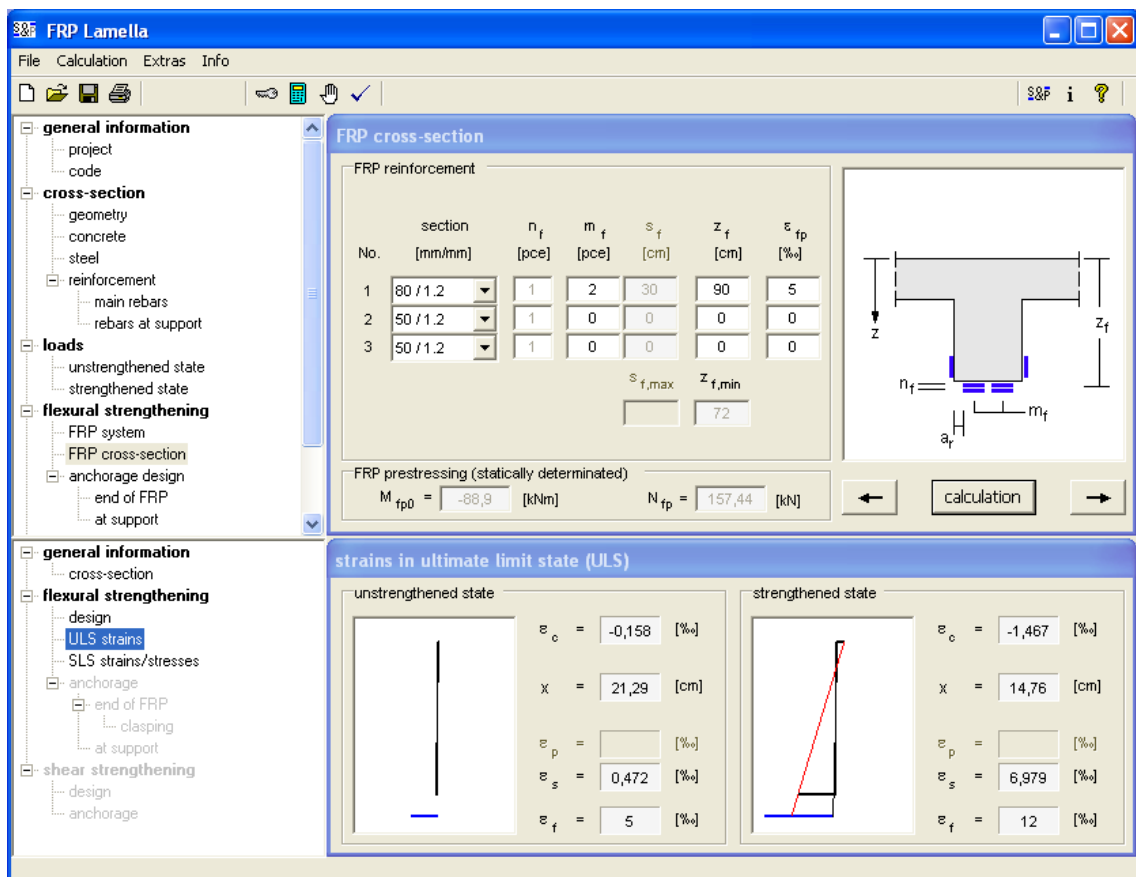

Figure 4: Software window showing selected FRP cross-section and prestress (top) and strain distribution of initial state (“unstrengthened state”, bottom left) and ultimate limit state (“strengthened state”, bottom right).

The software determines the required FRP cross-sectional area for the strengthened state and verifies the FRP bond strength and the shear capacity of the concrete element. 4 types of cross-sections are supported: slabs as well as rectangular beams, T-beams and I-beams. The equilibrium of internal and external forces and bending moments for different design situations is found by variation of the strain profile within the defined limits for each material. The implementation of non-linear stress-strain relations for concrete and reinforcing steel and the iterative solution procedure lead to precise results and economic amounts of FRP strengthening. Additionally the strain and stress distributions in ultimate limit state and service state can be controlled.

As mentioned previously, the design calculation for flexural strengthening with prestressed CFRP strips divides into three different proofs. At maximum bending moment, the required flexural capacity of the strengthened cross-section has to be checked. At the end anchorages, the effective transmission of the expected FRP tensile forces to the concrete has to be ensured. The third check of the bond capacity in-between the anchorages is comparable to unstressed FRP strips.

In Figure 4, a screenshot of the software interface is shown (vom Berg 2007). In the input window at the top, the cross-section and prestress of the FRP strengthening is selected. The result window at the bottom shows the initial strains on the left and strains in ultimate limit state on the right. The initial strains of concrete and rebars are very low as the element is only subjected to dead loads. The FRP is pre-strained to  $\epsilon_{f,prestres,d} = 5 \text{ ‰}$  and does not participate in load carrying yet. In ultimate limit state, the total FRP strain reaches the maximum of  $\epsilon_{f,max,d} = 12 \text{ ‰}$  under design loads. This leads to a much better exploitation of the FRP material than in unstressed strips without anchorages. As the concrete strain  $\epsilon_c$  in ultimate limit state is lower than the strain limit of  $\epsilon_{cu} = 3.5 \text{ ‰}$ , concrete crushing does not govern the design.

## 5 CONCLUSIONS

Prestressed CFRP strips allow higher exploitation of the FRP tensile strength and so a more economical use of the expensive material. Additionally, serviceability of the structure is improved more effectively by introducing a prestressing force and bending moment, counteracting the external loads. Since the prestressing force of the FRP strip cannot be anchored to the concrete by adhesive bond alone, mechanical anchoring devices are necessary. As the prestressing force, applied before the adhesive hardens, does not stress the adhesive bond, the tensile strength of the expensive CFRP can be exploited more economically than in unstressed strips. A new prestressing system, using conventional CFRP strips, steel anchor plates with self-undercutting anchor bolts is presented. The end anchorage of the strip is ensured by a combination of dowel action and increased adhesive bond due to the self-induced passive clamping force. The paper explains the mechanical principles and technical features of the system. Additionally a comprehensive but easy to use design software is presented, which considers the requirements of different national concrete design codes and FRP guidelines. The prestressing system is expected to be officially approved in Germany by the end of 2007.

## 6 REFERENCES

- Neubauer, U., Rostásy, F. S. 2001. Debonding mechanism and model for CFRP plates as external reinforcement for concrete members. *International Conference Composites in Construction CCC 2001*, Porto, Portugal.
- Suter, R. & Jungo, D. 2001. Vorgespannte CFK-Lamellen zur Verstärkung von Bauwerken, *Beton- und Stahlbetonbau 96*, Heft 5.
- Tan, K., et al. 2002. Evaluation Of CFRP-Systems For The Strengthening Of RC Slabs, *Interim Report*, Center For Infrastructure Engineering Studies, University of Missouri–Rolla, Missouri, USA.
- vom Berg, W. 2007. *FRP Lamella design software for flexural and shear strengthening with FRP materials according to Eurocode 2, Design basics and User manual*, bow ingenieure gmbh, Braunschweig, Hamburg, Germany.